



# TALIA

## Assembly Instructions

**Thank you for your purchase.**

Unpack all content and check to ensure that all of the parts are in proper condition. To help protect the environment, use the appropriate recycling and discarding methods for the packaging items.

Read ALL assembly instructions before beginning. If you have any questions, please contact your installer or Salamander Designs at 800-535-5659.

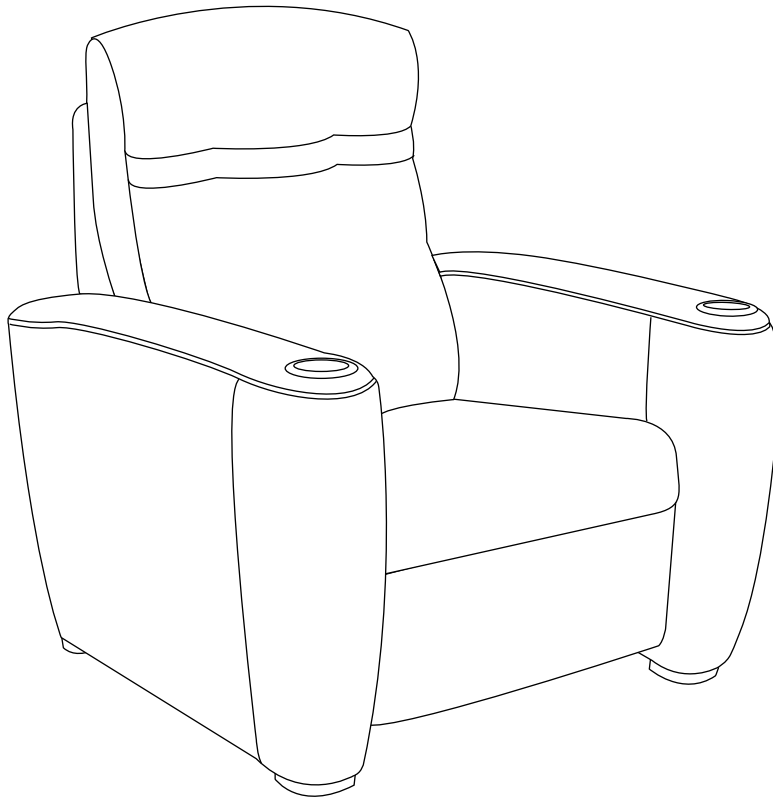

**Tool Required:**

Phillips Screwdriver



or power drill with phillips drive

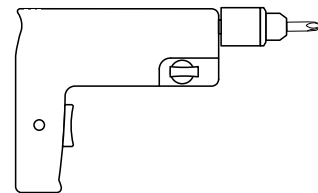

---

**PARTS** - Supplied with Armless, Left and Right-End Chairs

①

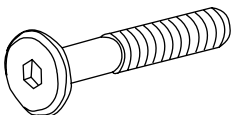

Connector Bolt

②

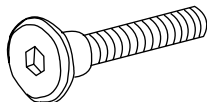

Connector Bolt

③

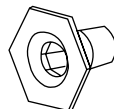

Hex Nut

④



Hex Wrench

# 1 Tactile Transducer - Optional

If you have purchased a Tactile Sound Transducer for your chair(s), install before connecting seats.

Remove back panel and screw transducer onto bolt on chair frame.

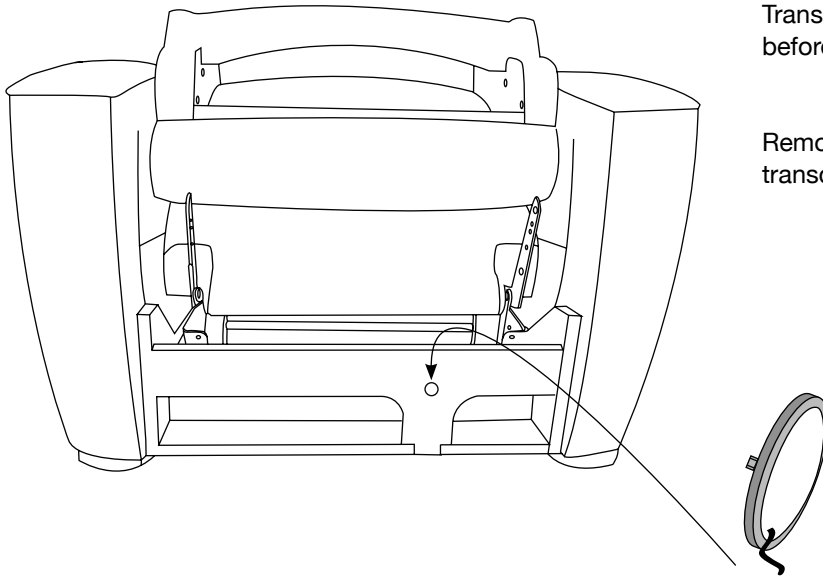

Tactile Transducer

# 2 Powered Seating

Connect power supply to control box as shown. Connection is located on the bottom of control box

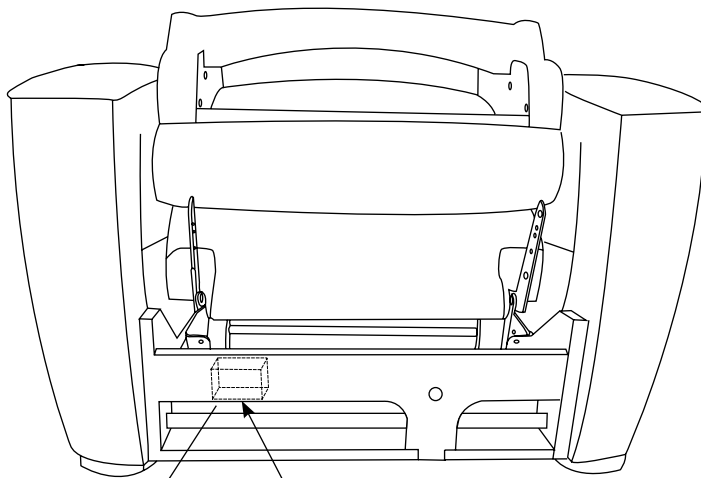

Control Box

Power Connection

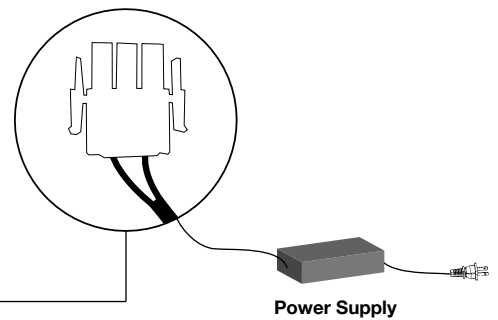

Power Supply

### 3 Connecting Seats to Arms (End Chair to Straight or Wedge Connector)

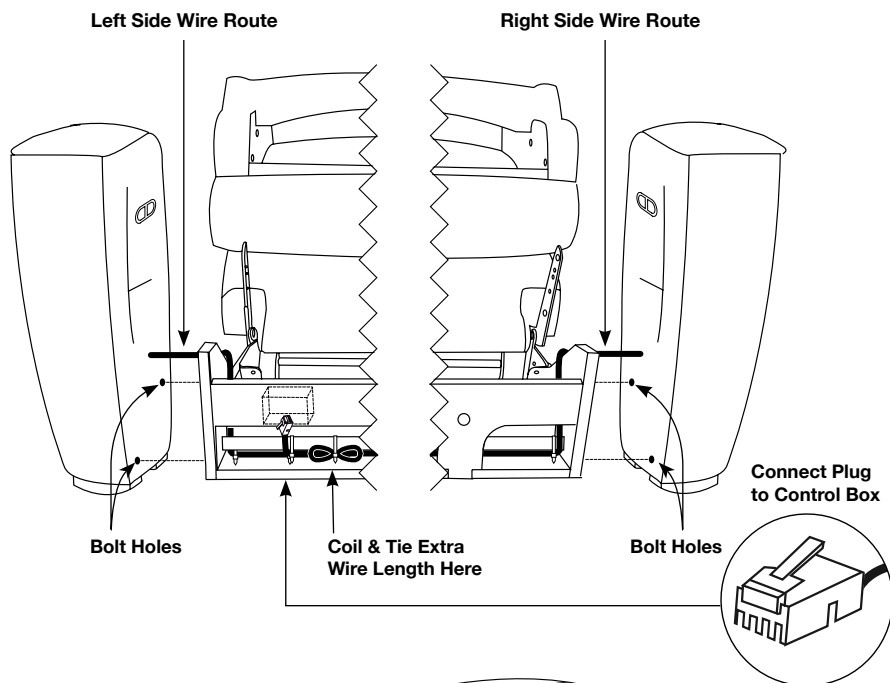

**A.** Align seats and connectors prior to assembly. Attention to switch location is necessary.

Align front and back bolt holes.

#### Powered Seating

For powered seating, connect in-arm switch to control box. Route wire as shown along horizontal bar away from the mechanism. Connect plug to control box and coil and tie off extra wire as shown.

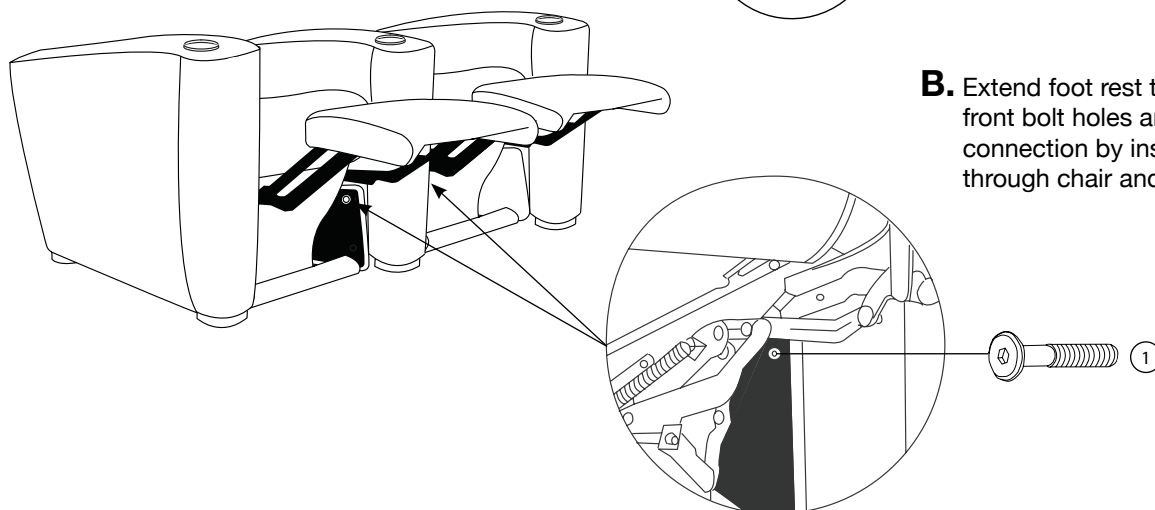

**B.** Extend foot rest to access front bolt holes and secure connection by inserting bolts through chair and into arm.

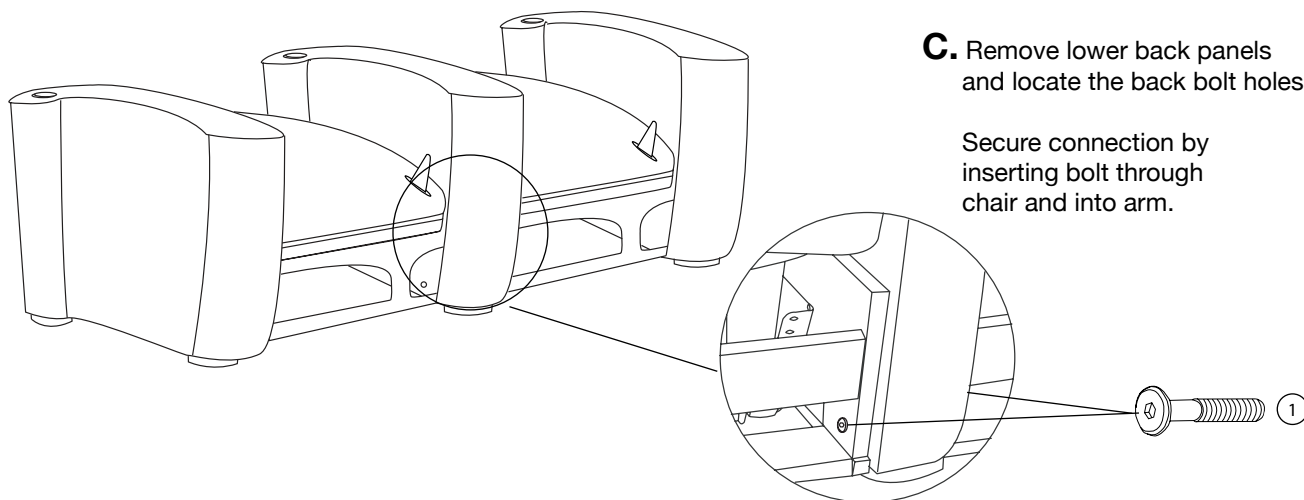

**C.** Remove lower back panels and locate the back bolt holes.

Secure connection by inserting bolt through chair and into arm.

## 4 Connecting Seat to Seat

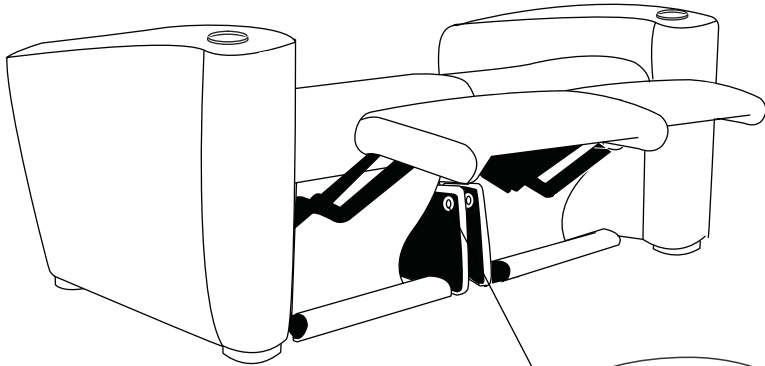

**A.** Extend foot rest to access front bolt holes.

Secure connection by inserting bolt through chair frames.

Align front and back bolt holes.

Fasten with nut.

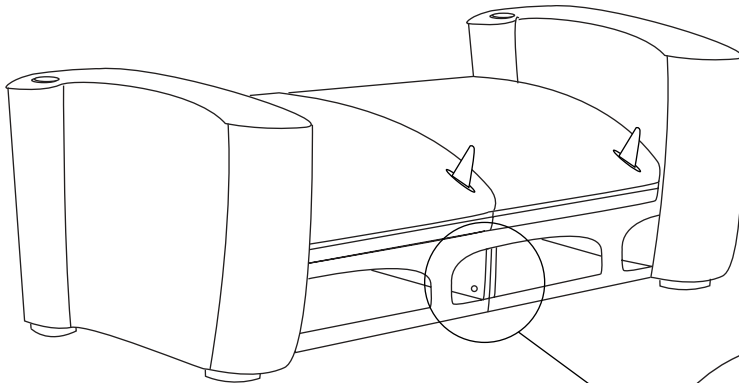
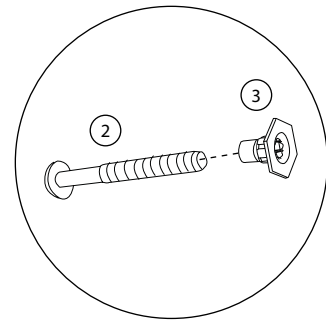
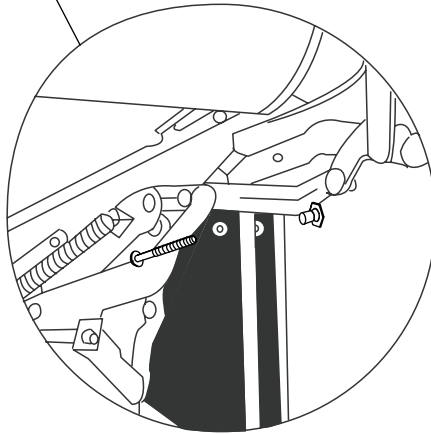

**B.** Remove lower back panel and locate the back bolt holes.

Secure connection by inserting bolt through chair frames.

Fasten with nut.

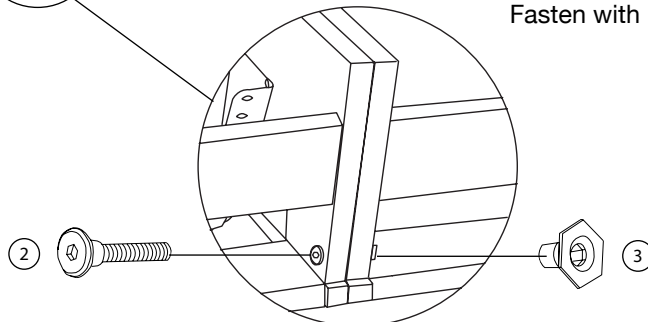

## 5 Attaching Back Rests

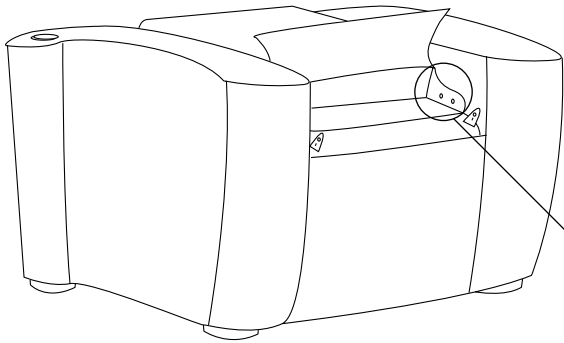

**A.** Lay backrest face down on seat and open lower access flap.

Remove four hand-tightened screws from the back rest frame.

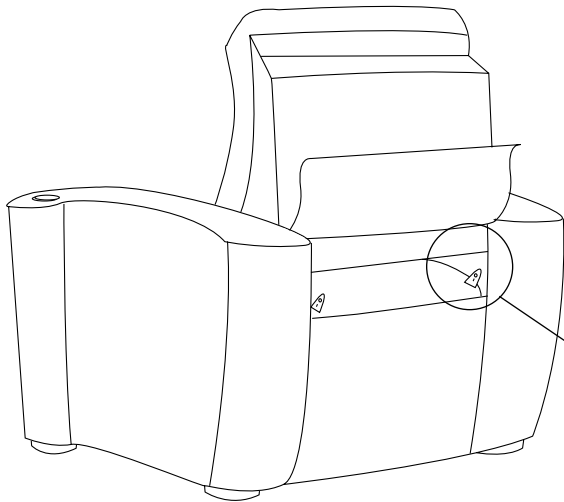
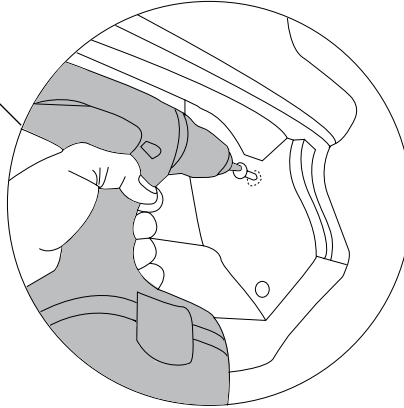

**B.** While holding access flap open, align the backrest screw holes to the upper and lower holes in the chair mechanism tongues.

Install and tighten screws.

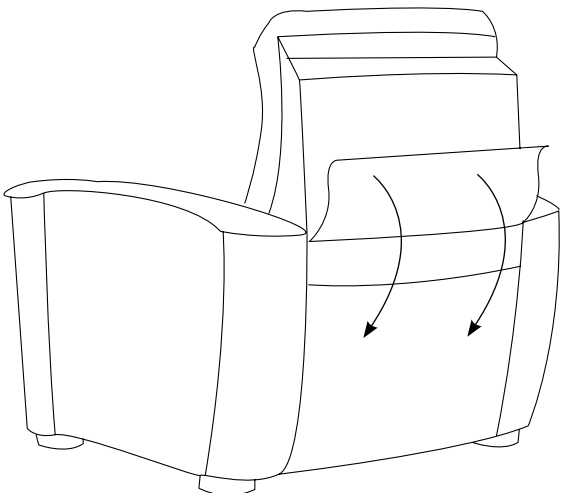
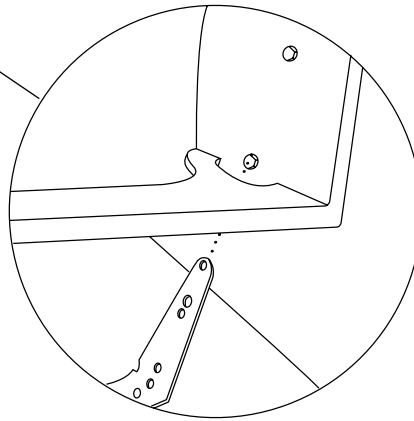

**C.** Fasten access flap neatly into place.

## Salamander Seating Limited Warranty

Salamander Designs Ltd. (Salamander) provides the following Limited Warranty. The Limited Warranties herein described for the specific products listed below shall be in lieu of any other warranty, expressed or implied, including but not limited to any implied warranty of merchantability or fitness for a particular use. These Limited Warranties do not cover damages incurred in shipment, failures caused by other products not supplied by Salamander, or failures due to accident, misuse, abuse or alteration of the product. Salamander's sole liability and the purchaser's exclusive remedy shall be for the repair, or at Salamander's option, for the replacement of the defective part as provided herein. Notwithstanding the above, if replacement parts for defective materials are not available, Salamander reserves the right to make reasonable compensation in lieu of repair or replacement. Liability for incidental or consequential damages under the warranty is excluded. Some states do not allow limitation of incidental or consequential damages. Therefore, the above limitation may not apply in certain instances. Defective product must be given Return Authorization by Salamander and is to be returned to the factory prepaid, in the original carton and packing materials. Any damage incurred in a shipment not in original packing shall be the responsibility of the owner. Warranty repairs will be returned to the owner prepaid, within the continental U.S.A. only. This warranty gives you specific legal rights and you may also have other rights which vary from state to state.

The Seating Limited Warranties provided below protect the original consumer purchaser only; no warranty is provided to business, commercial, rental, institutional or other non-residential users.

**MANUAL MECHANISM** - Salamander provides a three (3) year Limited Warranty on its standard (non-powered) reclining mechanism. This warranty covers the repair or replacement of the reclining mechanism against manufacturing defects when used in a normal manner.

**POWERED MECHANISM** - Salamander provides a one (1) year Limited Warranty on our powered reclining mechanism. This warranty covers the repair or replacement of the powered reclining mechanism against manufacturing defects when used in a normal manner.

**CUSHIONING** - Salamander provides a two (2) year Limited Warranty against tearing or collapsing due to defects in material or workmanship. Please note that all foams and composites naturally soften with use. This softening does not constitute a defect under the warranty.

**FRAME** - The frame is subject to a three (3) year Limited Warranty and covers only defects in material or workmanship of the frame under normal use.

**SUSPENSION** - The suspension system is subject to a three (3) year Limited Warranty with respect to the tearing or separation from the frame under normal use.

**FABRIC / LEATHER** - The Limited Warranty on the fabric covers defects in material or workmanship for one (1) year that result in seam failure, fabric separation, nap loss, leather splitting, natural scars opening, premature fading or pilling under normal conditions. The fabric Limited Warranty does not apply where there is evidence of excessive soiling, improper cleaning, abuse, or where the fabric has had a chemical treatment applied by the retail dealer or the consumer.

**WARRANTY PROCEDURE** - Claims should be made through the dealer from which the product was purchased. The dealer will contact Salamander Designs Ltd. (Salamander) for warranty service. An original sales order number/purchase order number will be required for warranty protection. Salamander's liability under this warranty is limited to repairing or replacing at Salamander's option any part or parts of the product found to be defective in material or workmanship within the applicable warranty period. Salamander in its sole discretion will determine the cause and nature of any defect, the necessity and manner of repair or replacement, and all other matters pertaining to the condition of the product.

**LABOR AND SHIPPING CHARGES** - Should you be entitled to receive a repair or replacement under this warranty, Salamander will pay the cost of labor, handling and shipping to the consumer for two (2) years from the date of purchase by the original consumer. After that date, the purchaser will be responsible for these costs.

## Leather Care

Leather is a natural product and variations in color can occur, along with minor flaws such as scars. We therefore recommend that you look after your chair by not exposing it to direct sunlight or placing it too close to a heat source, such as a radiator, which will cause the leather to dry.

To remove any dust and dirt we recommend vacuuming with a soft brush. To remove simple stains (water soluble) please use a soft cloth or sponge with a little water.



**SALAMANDER  
DESIGNS**

phone: 800-535-5659

web: [SalamanderDesigns.com](http://SalamanderDesigns.com)